

BUTTERFLY DAMPER



THE IDEAL BACKDRAFT DAMPER FOR SOLAR, FRESH AIR INTAKE, HEAT EXCHANGERS AND OTHER AIR DUCT APPLICATIONS

- ◆ Foam seal provides minimal leakage.
- ◆ No springs or metal hinges to go bad.
- ◆ Works for both horizontal or vertical applications.
- ◆ Ideal for intake or exhaust applications.
- ◆ Due to its unique design, it opens easily with normal air flow and closes by gravity.



FRESH AIR MANUFACTURING CO.

Technologies in Ventilation

649 N. Ralstin St., Meridian, ID 83642 * (208)884-8931 * 800-234-1903 * FAX: (208)884-8943

BUTTERFLY DAMPER



OPTIONS:

- ◆ Square to round models available.
(Customer provides measurements)
- ◆ Special mounting designs.
(Customer provides measurements)
- ◆ Larger sizes are available on request.

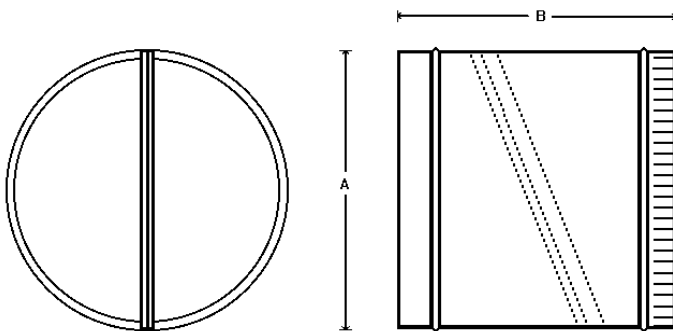

BUTTERFLY DAMPER DETAIL										
Diameter	4"	5"	6"	7"	8"	9"	10"	12"	14"	16"
Max. Height	4"	5"	6"	7"	8"	9"	10"	12"	14"	16"
Max. Length	6"	6"	6"	7"	8"	8"	7"	9"	12"	14"



FRESH AIR MANUFACTURING CO.
Technologies in Ventilation